

BENNING

World Class Power Solutions

norwatt@norwatt.es

www.norwatt.es



UPS ENERTRONIC S

Uninterruptible Power Supply
for AC-Loads





ENERTRONIC S

powerful, compact and cost efficiency

General remarks

The increasing use of information and data processing systems as well as computer-controlled automation systems requires a reliable uninterrupted power supply.

The ENERTRONIC S series ensures that voltage peaks, voltage distortions and voltage drops in the public mains have no effect on critical loads.

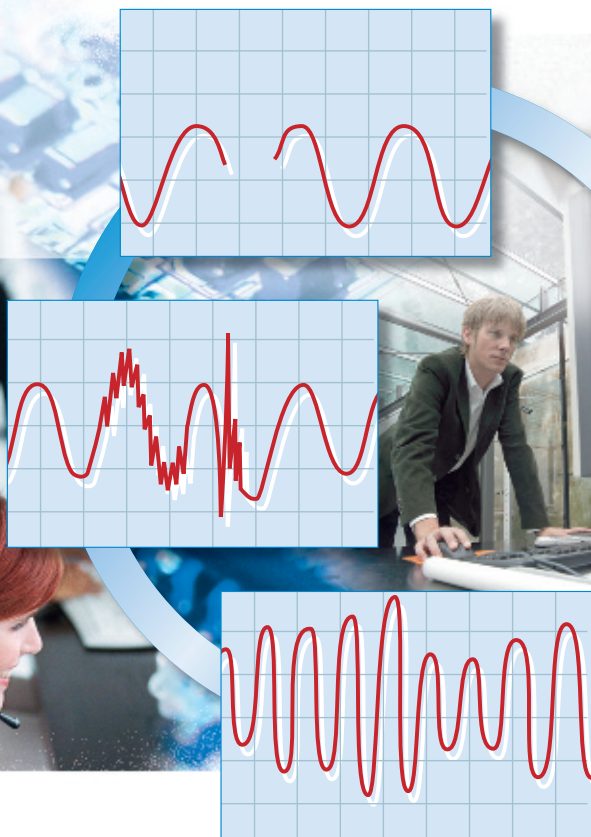

Fig. 1: Possible Irregularities



Fig. 2: ENERTRONIC S 5 kVA

Construction

The modular construction and redundancy are two features of the ENERTRONIC S series. Depending on the required power and the mains failure bypass time, the systems can be individually adapted to the load. As power demands increase, the system can be expanded.

The systems consist of 1,25 kVA power blocks which can be connected in parallel up to a max. output power of 10 kVA. In the event of one power block failing, the defective power block will be separated and the other blocks will continue operating without interruption. N+1 redundancy is therefore possible within the UPS systems. The complete redundancy of all electronic components on the power boards ensures maximum reliability of the UPS system.

In the standard version, each power block has a 36 V 7.2 Ah battery block. With a nominal load of 80% it is therefore possible to obtain a mains failure bypass time of 10 min. To obtain longer bypass times, it is possible to connect several battery blocks per UPS power block in parallel.

The systems are available in two different mechanical versions. Up to 5 kVA, both the UPS power blocks and the battery blocks for 10 min. are installed in one housing (see figure 2).

Systems from 6,25 to 10 kVA require separate electronic and battery housings (see figure 3).

Longer bypass times normally require additional battery housings.

In the standard version, the recharge time of the battery is approx. 6 hours. With longer bypass times, the battery charging time is correspondingly longer.

In such cases, it is possible to install one or several additional charging units with 8 A charging current to reduce the charging time.



ENERTRONIC S

technical specifications

Technical Data

		1,25 kVA	2,5 kVA	3,75 kVA	5 kVA	6,25 kVA	7,5 kVA	8,75 kVA	10 kVA	
Typ.		Online system with double conversion								
Voltage form		sinusoidal								
Output power	[VA]	1250	2500	3750	5000	6250	7500	8750	10000	
Active power	[W]	875	1750	2625	3500	4375	5250	6125	7000	
Input voltage		230 V single phase								
Input voltage range		184 - 264 V at 100 % load 110 - 264 V at 50 % load								
Input frequency		50/60 Hz \pm 2 % auto sense								
Power factor		$>$ 0,99 already at 20 % load								
Output voltage		230 V \pm 1 %								
Output frequency		50/60 Hz synchronised 50/60 Hz \pm 0,1 % quartz synchronised								
Power factor load		0,7								
Back-up-time										
	at 80 % Load	[min]							10	
	at 50 % Load	[min]							20	
Batteries		3 x 12 V 7,2 Ah sealed maintenance free lead acid battery per power board								
Dimensions	[mm]	475 x 270 x 570				475 x (2 x 270) x 570				
(H x W x D)										
Weight	[kg]	23,5	34	43	53	26,5 + 57,5	29 + 65	31,5 + 72,5	34 + 80	
Protection		IP 21								
EMC		EN 50091-2								

www.norwatt.es

www.norwatt.es

Display

Displayed values:

- Input voltage and input current, power, frequency
- Output voltage and output current, power, frequency
- Battery operating data, remaining time
- Total UPS operating time
- Battery test by means of charge state monitoring



Fig. 3: ENERTRONIC S 10 kVA

Fig. 4:
Display

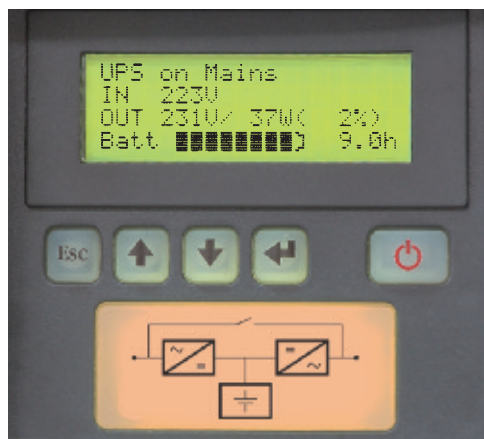

Other features

- Input power factor $>$ 0,99
- THDI $<$ 3 %
- Static bypass
- Class A/B (immunity/emission)
- Input frequency auto sense
- Plug&Play for gensets
- Noise level $<$ 40 dBA
- Long life battery control

ENERTRONIC S

diagnosis and monitoring

Features

Ideal sine output

using double conversion and online operation (VFI SS 111)

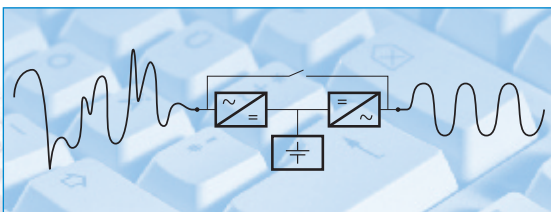

Sinusoidal current consumption (PFC)

according to European standards

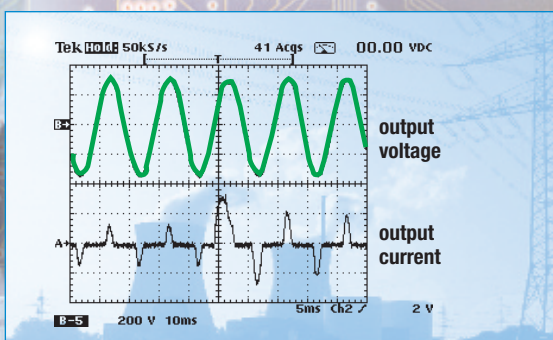
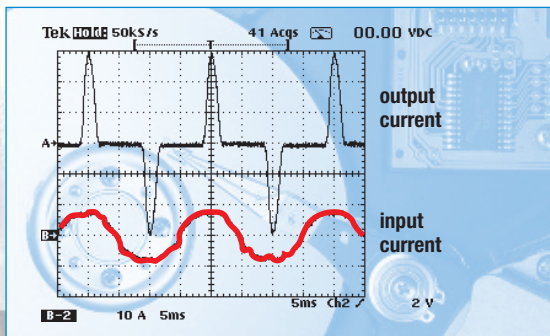

High short circuit current

150 % for 30 sec., 200 % for 5 sec.

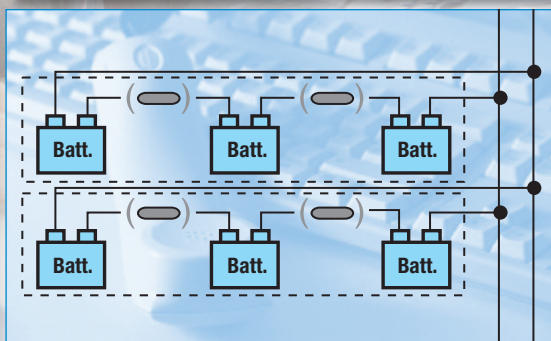

Battery redundancy

with battery blocks connected in parallel

Options

- External manual bypass
- Relay board with three relays
- Remote display



Settings:

- Selection of input and output frequency 50/60 Hz
- Output voltage setting
- Max. battery operating time at battery low voltage
- Bypass settings
- Operating mode online - offline
- Starting operation
- Automatic start after mains return
- Automatic battery test
- Operation with an emergency generator
- Switch-off of the acoustic signal
- Reset of the monitored limiting values
- Redundancy N+X

Shutdown software

The Shutdown Software UPS Management is designed for a controlled shut down of running PC operations before the battery is discharged and the system switches off because of

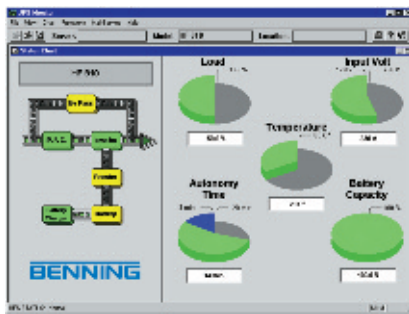

Fig. 5:
Monitoring
software

low battery voltage. It is able to operate with most common operating systems such as Windows, Novell, Linux and Unix. As it is able to manage not only the server but also the clients in one network, this software is the ideal network manager. It monitors the most important UPS parameters (input voltage, used capacity in %, battery capacity and available bypass time), gives a warning to all the users of the network and switches the UPS on and off.

ENERTRONIC S

1,25 kVA – 10 kVA

Type table

Output voltage [kVA]	Type	Battery for minutes	Dimensions H x W x D [mm]	Efficiency [%]
1,25	ENERTRONIC S 1-1-1,25-10	10	480 x 270 x 560	90,0
1,25	ENERTRONIC S 1-1-1,25-20	20	480 x 270 x 560	90,0
1,25	ENERTRONIC S 1-1-1,25-30	30	480 x 270 x 560	90,0
1,25	ENERTRONIC S 1-1-1,25-60	60	480 x (2 x 270) x 560	90,0
1,25	ENERTRONIC S 1-1-1,25-120	120	480 x (2 x 270) x 560	90,0
2,5	ENERTRONIC S 1-1-2,5-10	10	480 x 270 x 560	90,0
2,5	ENERTRONIC S 1-1-2,5-20	20	480 x 270 x 560	90,0
2,5	ENERTRONIC S 1-1-2,5-30	30	480x (2 x 270) x 560	90,0
2,5	ENERTRONIC S 1-1-2,5-60	60	480 x (2 x 270) x 560	90,0
2,5	ENERTRONIC S 1-1-2,5-120	120	480 x (3 x 270) x 560	90,0
3,75	ENERTRONIC S 1-1-3,75-10	10	480 x 270 x 560	90,0
3,75	ENERTRONIC S 1-1-3,75-20	20	480 x (2 x 270) x 560	90,0
3,75	ENERTRONIC S 1-1-3,75-30	30	480 x (2 x 270) x 560	90,0
3,75	ENERTRONIC S 1-1-3,75-60	60	480 x (2 x 270) x 560	90,0
3,75	ENERTRONIC S 1-1-3,75-120	120	480 x (3 x 270) x 560	90,0
5,0	ENERTRONIC S 1-1-5,0-10	10	480 x 270 x 560	90,0
5,0	ENERTRONIC S 1-1-5,0-20	20	480 x (2 x 270) x 560	90,0
5,0	ENERTRONIC S 1-1-5,0-30	30	480 x (2 x 270) x 560	90,0
5,0	ENERTRONIC S 1-1-5,0-60	60	480 x (3 x 270) x 560	90,0
5,0	ENERTRONIC S 1-1-5,0-120	120	480 x (4 x 270) x 560	90,0
6,25	ENERTRONIC S 1-1-6,25-10	10	480 x (2 x 270) x 560	90,0
6,25	ENERTRONIC S 1-1-6,25-20	20	480 x (2 x 270) x 560	90,0
6,25	ENERTRONIC S 1-1-6,25-30	30	480 x (3 x 270) x 560	90,0
6,25	ENERTRONIC S 1-1-6,25-60	60	480 x (4 x 270) x 560	90,0
6,25	ENERTRONIC S 1-1-6,25-120	120	480 x (5 x 270) x 560	90,0
7,5	ENERTRONIC S 1-1-7,5-10	10	480 x (2 x 270) x 560	90,0
7,5	ENERTRONIC S 1-1-7,5-20	20	480 x (3 x 270) x 560	90,0
7,5	ENERTRONIC S 1-1-7,5-30	30	480 x (3 x 270) x 560	90,0
7,5	ENERTRONIC S 1-1-7,5-60	60	480 x (4 x 270) x 560	90,0
7,5	ENERTRONIC S 1-1-7,5-120	120	480 x (6 x 270) x 560	90,0
8,75	ENERTRONIC S 1-1-8,75-10	10	480 x (2 x 270) x 560	90,0
8,75	ENERTRONIC S 1-1-8,75-20	20	480 x (3 x 270) x 560	90,0
8,75	ENERTRONIC S 1-1-8,75-30	30	480 x (3 x 270) x 560	90,0
8,75	ENERTRONIC S 1-1-8,75-60	60	480 x (5 x 270) x 560	90,0
8,75	ENERTRONIC S 1-1-8,75-120	120	480 x (7 x 270) x 560	90,0
10	ENERTRONIC S 1-1-10-10	10	480 x (2 x 270) x 560	90,0
10	ENERTRONIC S 1-1-10-20	20	480 x (3 x 270) x 560	90,0
10	ENERTRONIC S 1-1-10-30	30	480 x (3 x 270) x 560	90,0
10	ENERTRONIC S 1-1-10-60	60	480 x (5 x 270) x 560	90,0
10	ENERTRONIC S 1-1-10-120	120	480 x (8 x 270) x 560	90,0

Specifications are subject to change without notice.