

MRX Ni-Cd battery

The compact high-energy railway backup battery



norwatt@norwatt.es

www.norwatt.es

MRX Ni-Cd battery





norwatt@norwatt.es

www.norwatt.es

Saft: delivering the energy to move the railway industry forward

Saft has been a trusted partner for the world's leading railway industry players for over 50 years. It provides on-board solutions that deliver secure energy for transportation applications based on a wide range of dependable battery technologies. Saft products are designed to meet the challenges of reliability, safety and security of today's complex railway landscape.



The MRX Ni-Cd battery

Secure the energy backup for your train's vital electrical systems with the highly compact, fully integrated, fail-safe MRX battery package

The MRX battery combines proven Ni-Cd reliability with Sintered/PBE efficiency in an ultra-light and compact format. 30 % lighter than other Ni-Cd batteries, the MRX backup energy package enables you to achieve significant increases in passenger carrying capacity, enhance passenger comfort and optimise safety and profitability.

MRX is a highly compact Ni-Cd S/PBE block battery. Its high energy performance is a perfect fit for the continuous, everyday usage required of on-board energy backup on all types of modern electric train.

- Urban transport: metros, tramways, tram-trains, airport shuttles
- Regional transport: EMU, DMU (Electric and Diesel Multiple Units)
- Intercity transport: high-speed trains, electric locomotives, passenger coaches

MRX integrated on-board systems provide a reliable, always available source of high energy, that ensures:

- Passenger safety (on-board signalling, security lighting, door control and communication networks)
- Passenger comfort (ventilation, air-conditioning, lighting, Wi-Fi)
- Fail-safe train start-up (pantograph lift-up, computing, electronics)

Compact, lightweight and adaptable, MRX ensures that energy is always available. So you can rest assured that your service will always meet passenger expectations and contribute to their overall satisfaction.



The MRX Ni-Cd battery

Delivering compact high-energy performance for your peace of mind



The benefits of the MRX battery's compact format and low Life Cycle Cost (LCC) combined with its durability and flexibility are the ideal standard for your railway energy backup.

Free up space and reduce weight

The MRX battery's compact design offers an overall 30 % reduction in volume and weight compared with an ordinary Ni-Cd battery.

- The ultra-thin separator and S/PBE technology are the key features of this very compact technology.
- The block concept is another space saver compared with regular side-by-side assembly of single cells.
- These all result in a reduction in overall weight for the battery system.

Save money on maintenance and replacements

Your investment in MRX translates into a very low Life Cycle Cost. MRX's superior design is far more economical in the long run, outlasting all other types of batteries and drastically reducing maintenance.

- Saft's S/PBE Ni-Cd technology is field-proven to last over 15 years.
- The integrated Water Filling System makes the topping-up procedure rapid, safe and easy. Usually, this operation only needs to be performed every 2 years, significantly decreasing maintenance costs.
- Saft's Ni-Cd technology eliminates the issue of sudden death, guaranteeing permanent availability for train start-up and a constant supply of backup energy whenever needed.

Discharge at different current rates at 20°C

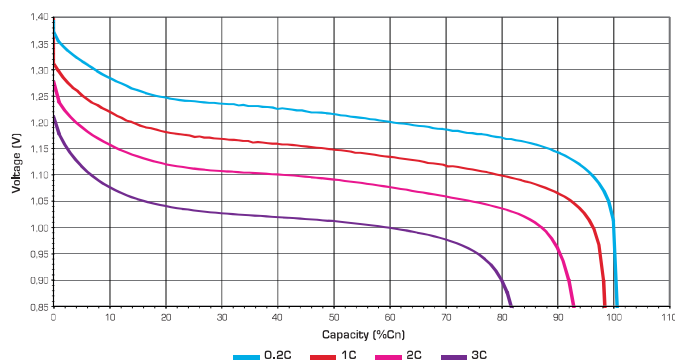

Discharge at C₅ current rate at different temperatures

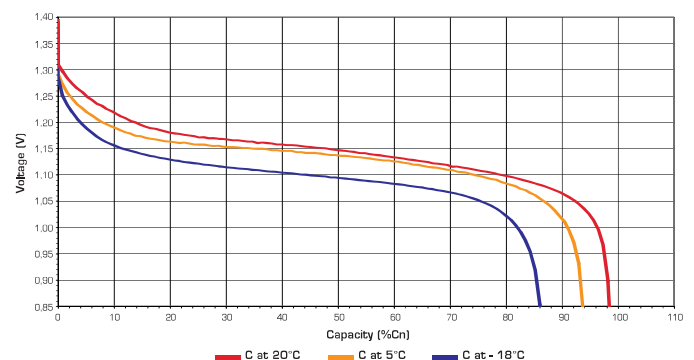

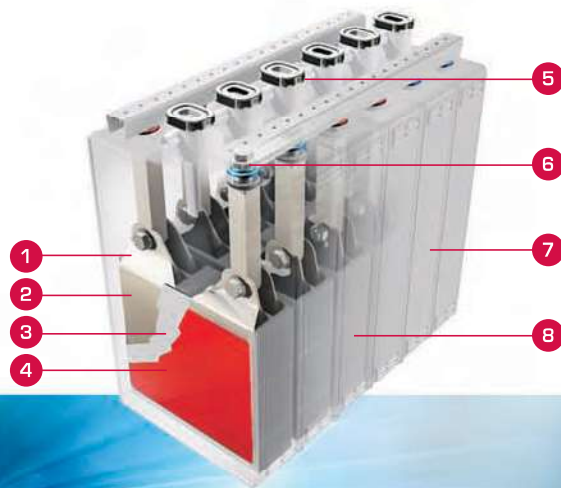

- 1 Wrapped plate stack
- 2 Positive plate
- 3 Ultra-thin separator
- 4 Negative plate
- 5 Integrated Water Filling System
- 6 Female terminal pole bolt
- 7 Thermo-welded block construction
- 8 Flame retardant container



Ensure reliable energy for safety, under a broad range of tough conditions

MRX is ideally adapted for the demanding requirements of railway backup in any environment, including very harsh conditions. The MRX design features also go much further than other batteries in terms of safety operations. It helps you to anticipate ever more stringent regulations to ensure continued compliance.

- MRX performs ideally at temperatures from -20°C to $+50^{\circ}\text{C}$.
- MRX resists temperature extremes of -50°C and $+70^{\circ}\text{C}$.
- MRX's robust, flame retardant plastic container is highly resistant to shocks and vibrations.

Take advantage of a perfect fit, whatever your specification

The MRX modular concept is fully adaptable to suit the diversity of today's railway designs and configurations, providing the flexibility to suit your own train's specifications.

- 18 steps in a wide range of capacities from 70 to 520 Ah offers the closest fit to each specific need.
- MRX's block modularity makes the battery easy to design and to install.
- MRX's common cross-section throughout the range allows for a high level of tray standardisation.

Full conformity with quality, safety and environmental standards

- Electrical: exceeding the medium "M" type requirements of IEC 60 623, also significantly exceeds UIC 854 requirements.
- Fire & smoke: NFF 16101-16102, DIN 5510, UNI IEC 11170-3, UL 94-V0.
- Shocks & vibrations: IEC 61 373.
- Quality: ISO 9001, IRIS, Saft world class continuous improvement program.
- Environment: fully recycled, ISO 14001, RoHS.

Chargeability with temperature compensation

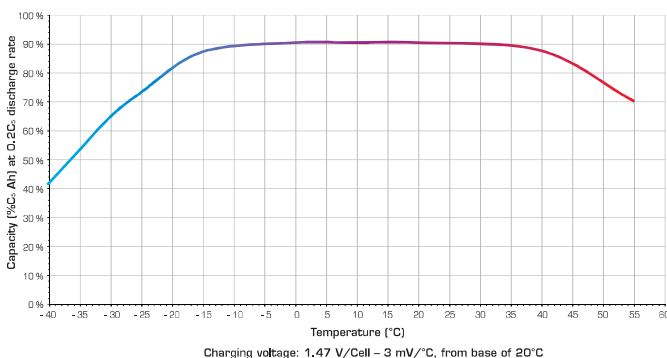

The MRX Ni-Cd battery

A solution to fit all your needs...

norwatt@norwatt.es

www.norwatt.es



Block type	Ah	Reserve (cm³)	Length (mm)*						Weight (kg)*					
			Number of cells per block						Number of cells per block					
			1	2	3	4	5	10	1	2	3	4	5	10
MRX 70	70	375				158	196	384				13	16	31
MRX 80	80	375				158	196	384				13	16	32
MRX 90	90	370				158	196	384				14	17	34
MRX 100	100	465				189	234					16	19	
MRX 115	115	460				189	234					17	20	
MRX 130	130	520				209	259					18	22	
MRX 145	145	750				309	384					26	31	
MRX 160	160	750				309	384					26	32	
MRX 180	180	740				309	384					28	34	
MRX 200	200	930			279	370					23	31		
MRX 230	230	920			279	370					24	33		
MRX 260	260	1,040			310	411					27	36		
MRX 280	280	1,110	121	234					10	21				
MRX 300	300	1,395	143	279					12	23				
MRX 350	350	1,380	143	279					12	24				
MRX 400	400	1,560	159	310					14	27				
MRX 460	460	1,840	189	370					16	33				
MRX 520	520	2,080	209	411					18	36				

* The block length and weight are determined by the number of cells in the block.

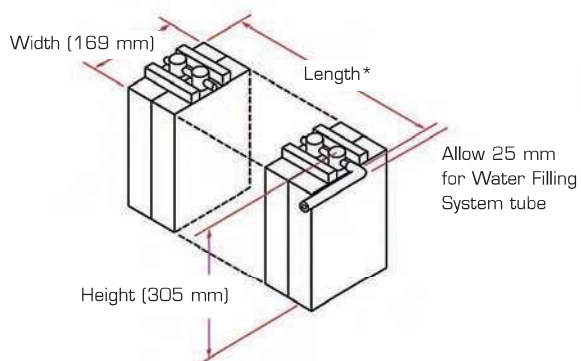

... everywhere in the world



"After 8 years in service our Saft MRX batteries are still performing very well, with zero failures, fewer and easier maintenance operations and an obviously longer life than L/A batteries."

A deputy workshop manager in UK

"Switching from lead acid to MRX batteries has enabled us to achieve a major increase in battery capacity and higher performance while keeping our existing battery boxes."

A chief electrical engineer in France

"Our equipment operates in a very harsh environment. The Ni-Cd MRX battery provides us the high energy levels we need, even at - 20°C and below."

A senior maintenance manager in Sweden

MRX Ni-Cd battery



"Designed for optimal integration in battery systems, we installed MRX in our trains as easily as a plug and play solution."

A senior designer in US

"After many years using lead acid batteries, facing traffic interruptions and heavy maintenance costs, we switched to MRX, which provides reliability, an integrated Water Filling System and low LCC."

A German maintenance manager for a tramway operator

"The key factors in Saft's success are its advanced battery technology combined with its high level of service and local support with service locations across the globe."

A purchaser for a Chinese metro company

► For our sales contacts, visit our web site: www.saftbatteries.com

As part of its environmental commitment, Saft gives priority to recycled raw materials over virgin raw materials, reduces its plants' air and water releases year after year, minimizes water usage, reduces fossil energy consumption and associated CO₂ emissions, and ensures that its customers have recycling solutions for their spent batteries.

Regarding industrial Ni-Cd batteries, Saft has had partnerships for many years with collection companies in most EU countries, in North America and in other countries. This collection network receives and dispatches our customers' batteries at the end of their lives to fully approved recycling facilities, in compliance with the laws governing trans-boundary waste shipments.

This collection network is undergoing minor adaptations to meet the requirements of the EU batteries directive. A list of our collection points is available on our web site.

In other countries, Saft assists users of its batteries in finding environmentally sound recycling solutions. Please contact your sales representative for further information.



**Saft is committed
to the highest standards
of environmental stewardship**



Document n° 21786-2-1209
Edition: December 2009

Data in this document is subject to change without notice and becomes contractual only after written confirmation.

Photo credits: Saft, Corbis, Fotolia.

Société anonyme au capital de 31 944 000 €
RCS Bobigny B 383 703 873

Attitudes design&communication - 8870/2

