

Primary lithium battery

G 54/3

3.0 V Primary lithium-sulfur dioxide (Li-SO₂)
 High drain capability
 5/4 C-size spiral cell



norwatt@norwatt.es

www.norwatt.es

Benefits

- High and stable discharge voltage
- High pulse capability
- Performance not affected by cell orientation
- Long storage possible before use
- Ability to withstand extreme temperature

Key features

- Low self-discharge rate
(less than 2 % after 1 year of storage at +20°C)
- Hermetic glass-to-metal sealing
- Built-in safety vent
(at the negative end of the cell)
- Restricted for transport *(class 9)*
- Meets shock, vibration and other environmental requirements of military specifications
- Made in UK

Main applications

- Radiocommunications and other military applications
- Beacons and Emergency Location Transmitters
- Sonobuoys
- Life jacket lights
- Professional electronics
- Missiles

Cell size reference

5/4 R14 - 5/4 C

Electrical characteristics

(typical values relative to cells stored for one year or less at +30°C max.)

Nominal capacity <i>(at 0.2 A +20°C 2.0 V cut-off. The capacity restored by the cell varies according to current drain, temperature and cut-off)</i>	5.0 Ah
Open circuit voltage (at +20°C)	3.0 V
Nominal voltage (at 0.5 A +20°C)	2.8 V
Nominal energy	14 Wh
Maximum recommended continuous current <i>(to avoid over-heating)</i>	2.5 A
Pulse capability: Typically up to 5 A. <i>(The voltage readings may vary according to the pulse characteristics, the temperature and the cell's previous history. Fitting the cell with a capacitor may be recommended in severe conditions. Consult Saft)</i>	
Storage (recommended) (possible without leakage)	+30°C (+86°F) max +85°C (+185°F) max
Operating temperature range <i>(Operation above ambient T may lead to reduced capacity and lower voltage readings at the beginning of pulses. Consult Saft)</i>	-60°C/+70°C (-76°F/+158°F)

Physical characteristics

Diameter (max)	25.6 mm (1.01 in)
Height (max)	60.2 mm (2.37 in)
Typical weight	58 g (2.05 oz)
Li metal content	1.5 g

Standard cell comes with protruding positive end-cap.
 Finish with tabs available on request.



G 54/3

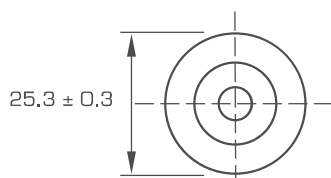
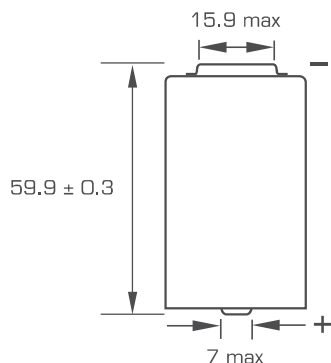

Overall dimensions in mm

Handling precautions

- Cell is pressurised.
- Do not puncture, open or mutilate.
- Do not obstruct the safety vent mechanism.
- Do not short circuit or charge.
- Do not expose to fire or temperatures above +70°C (+158°F).

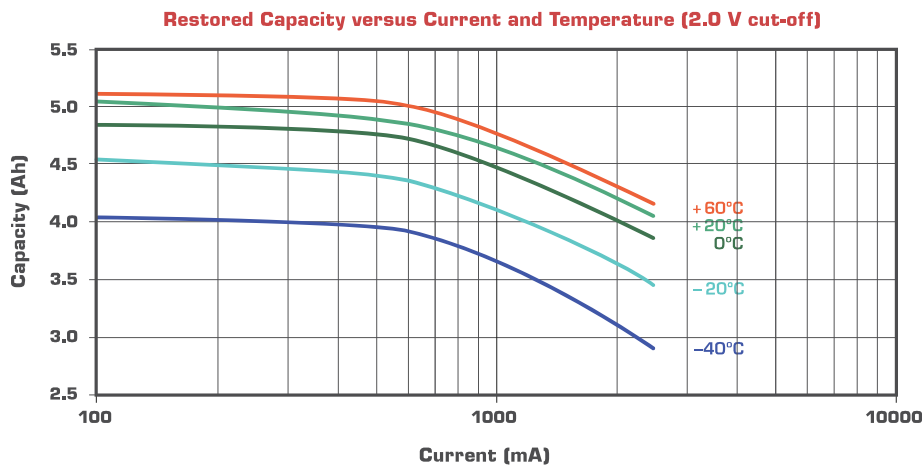
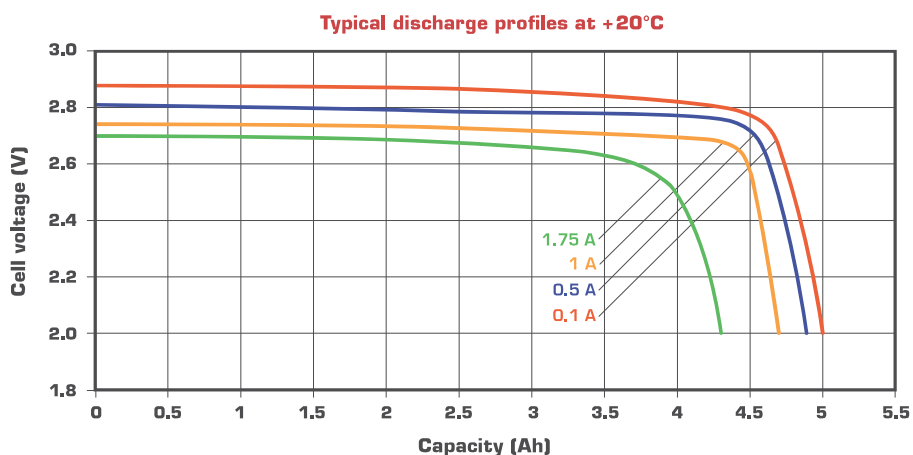
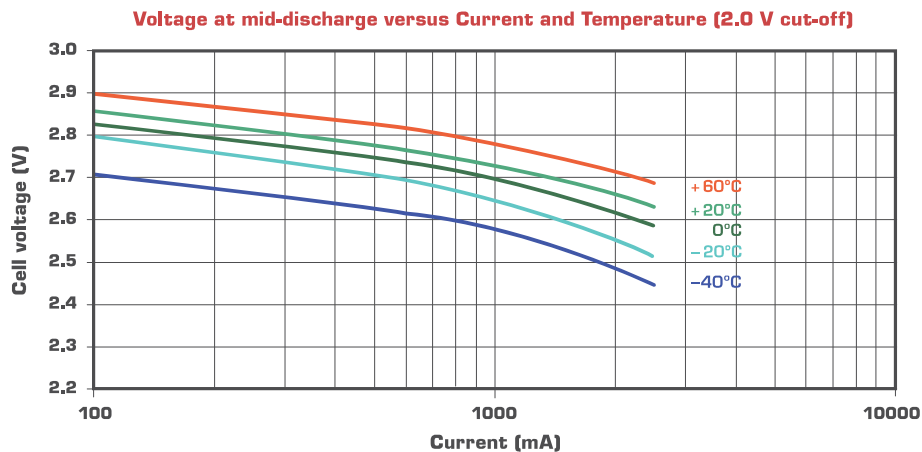

Doc. N° 31093-2-0209

Information in this document is subject to change without notice and becomes contractual only after written confirmation by Saft.

For more details on primary lithium technologies please refer to Primary Lithium Batteries Selector Guide Doc N° 31048-2.

Published by the Communications Department.

Photo credit: Saft.

Société anonyme au capital de 31 944 000€

RCS Bobigny B 383 703 873

Produced by Arthur Associates Limited.

