

Primary lithium batteries

LO 26 SXC

3.0 V Primary lithium-sulfur dioxide (Li-SO₂)
 High capacity, 9.2 Ah
 High drain D-size cell



Key features

- Enhanced capacity
- High and stable discharge voltage
- Performance not affected by cell orientation
- Low self discharge rate (*less than 3% after 1 year of storage at +20°C*)
- Hermetic glass-to-metal sealing
- Built-in safety vent (at the negative end of the cell)
- Restricted for transport (class 9)
- Meets shock, vibration and other environmental requirements of military specifications
- Made in the USA

Main applications

- Radiocommunications and other military applications
- Beacons and Emergency Location Transmitters
- Sonobuoys
- Missiles

etc...

Cell size reference	R20 - D
Electrical characteristics	
<i>(typical values for cells stored for one year or less)</i>	
Nominal capacity <i>(at 250 mA +20°C 2.0 V cut off. The capacity restored by the cell varies according to current drain, temperature and cut off).</i>	9.2 Ah
Open circuit voltage (at +20°C)	3.0 V
Nominal voltage (at 0.5 A +20°C)	2.8 V
Maximum recommended continuous current <i>(to avoid over-heating. Higher currents possible, consult Saft).</i>	2.5 A
Pulse capability : Up to 10 A. <i>Varies according to pulse characteristics (frequency, duration), temperature, cell history (storage conditions prior to usage) and the application's acceptable minimum voltage. Consult Saft.</i>	
Storage (recommended) <i>(possible without leakage)</i>	+30°C /+86°F max -60°C (-76°F) / +85°C (+185°F)
Operating temperature range	-60°C (-76°F) / +71°C (+160°F)
<i>(Short excursions up to 85°C possible at currents below 1 A).</i>	
Physical characteristics	
Diameter (max)	34.2 mm (1.345 in)
Height (max; finish without radial tabs)	59.3 mm (2.33 in)
Typical weight	85 g (3 oz)
Li metal content	2.7 g
Standard cell comes with resin potting in the topshell area and two radial 0.15 mm - thick nickel tabs	
Finish with positive button on request Finish with individual fuse on request	

LO 26 SXC

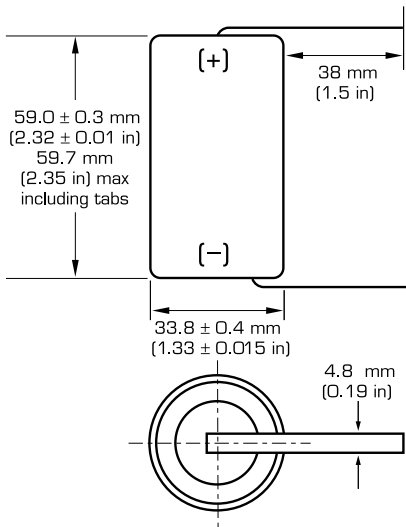

Overall dimensions

Handling precautions

- Cell is pressurized.
- Do not puncture, open or mutilate.
- Do not obstruct the safety vent mechanism.
- Do not short circuit or charge.
- Do not expose to fire or temperatures above +70°C (+160°F).

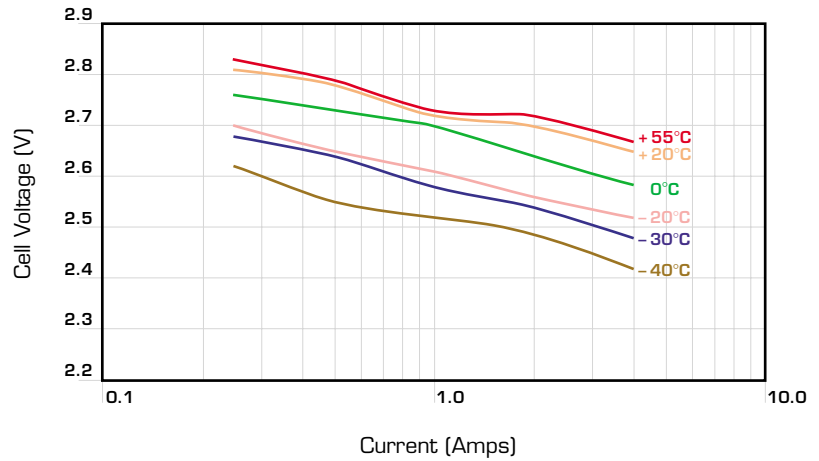

Voltage at mid-discharge versus Current and Temperature (2.0 V cut off)

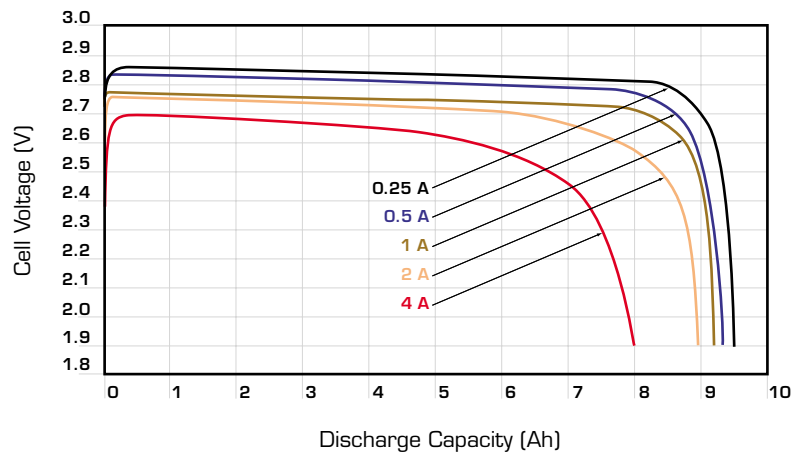

Typical discharge profiles at +20°C

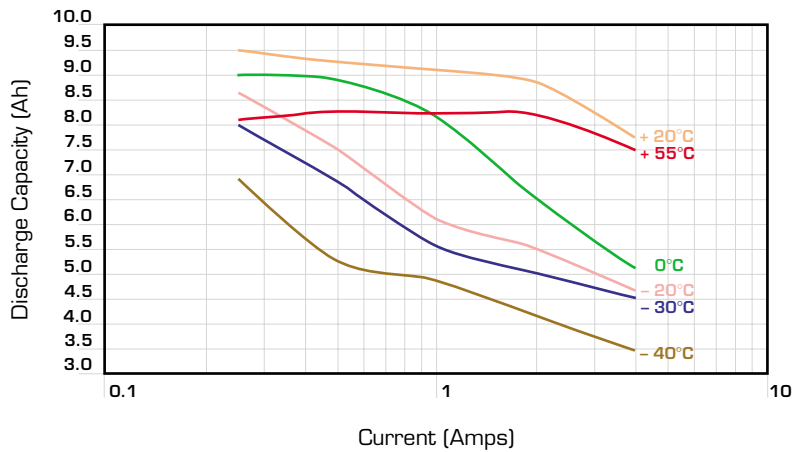

Capacity versus Current and Temperature - 2.0 V cut off

Doc. N° 31047-2-0604
Published by the Communications Department

Information in this document is subject to change without notice and becomes contractual only after written confirmation by Saft.
For more details on primary lithium technologies please refer to Primary Lithium Batteries Selector Guide Doc N° 31048-2-0604.
Photo credit: Saft
Produced by Arthur Associates

Société anonyme au capital de 31 944 000€
RCS Bobigny B 383 703 873